

NOZZLE INDEX

Connection	Size	Type	DIN
N1	Rp 2	Inlet	DIN 2999
N2	Rp 2	Outlet	DIN 2999
N3	Rp 1/2	Vent	DIN 2999
N4	Rp 1/2	Drain	DIN 2986
N5	Rp 1/2	Drain	DIN 2986

SPECIFICATION

Number of cartridges	5
Cartridge length	744-762 mm
Max. allow. pressure	10 bar
Test pressure	14,3 bar
Max. allow. temperature	-10/+80°C
Volume	45 l
Material housing	AISI 316
Material gasket	O-ring FPM
Material bolts	Stainless steel
Weight	47 kg

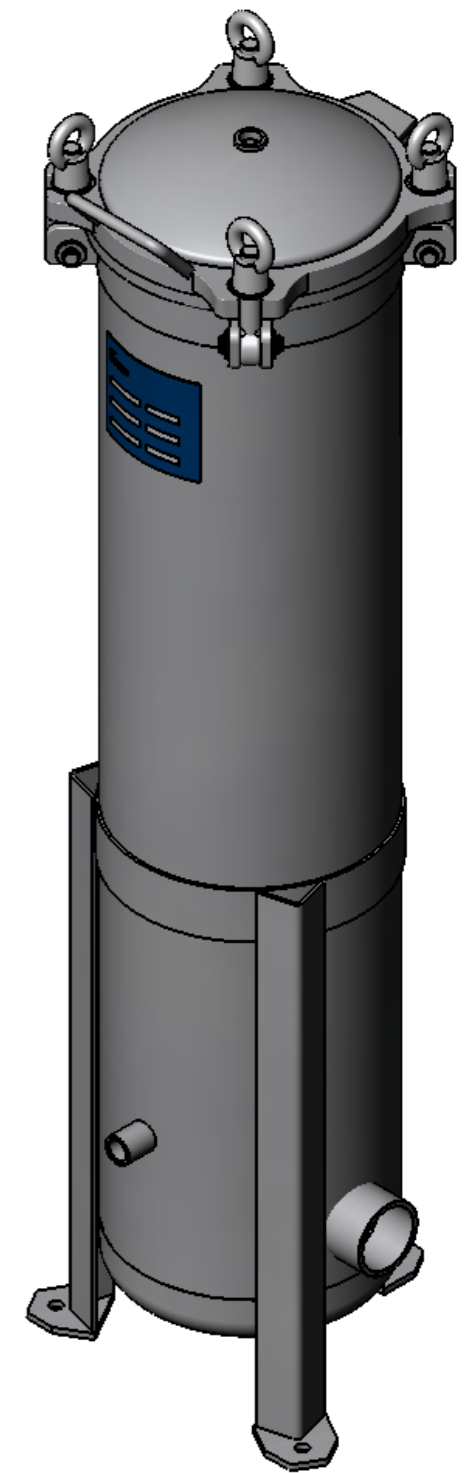

Date	09.01.2014	Name	Leekes	Type	5FWK3-10/G50-A4
				Article-No.	
				Associated Drawing:	10-1163 Rev.0

FUHR GmbH
 Am Weinkastell 14
 55270 Klein-Winternheim